

NOT AT ALL TIMES

FROM C149 ON
PAGE 25-1

* MANUAL
** AUTOMATIC

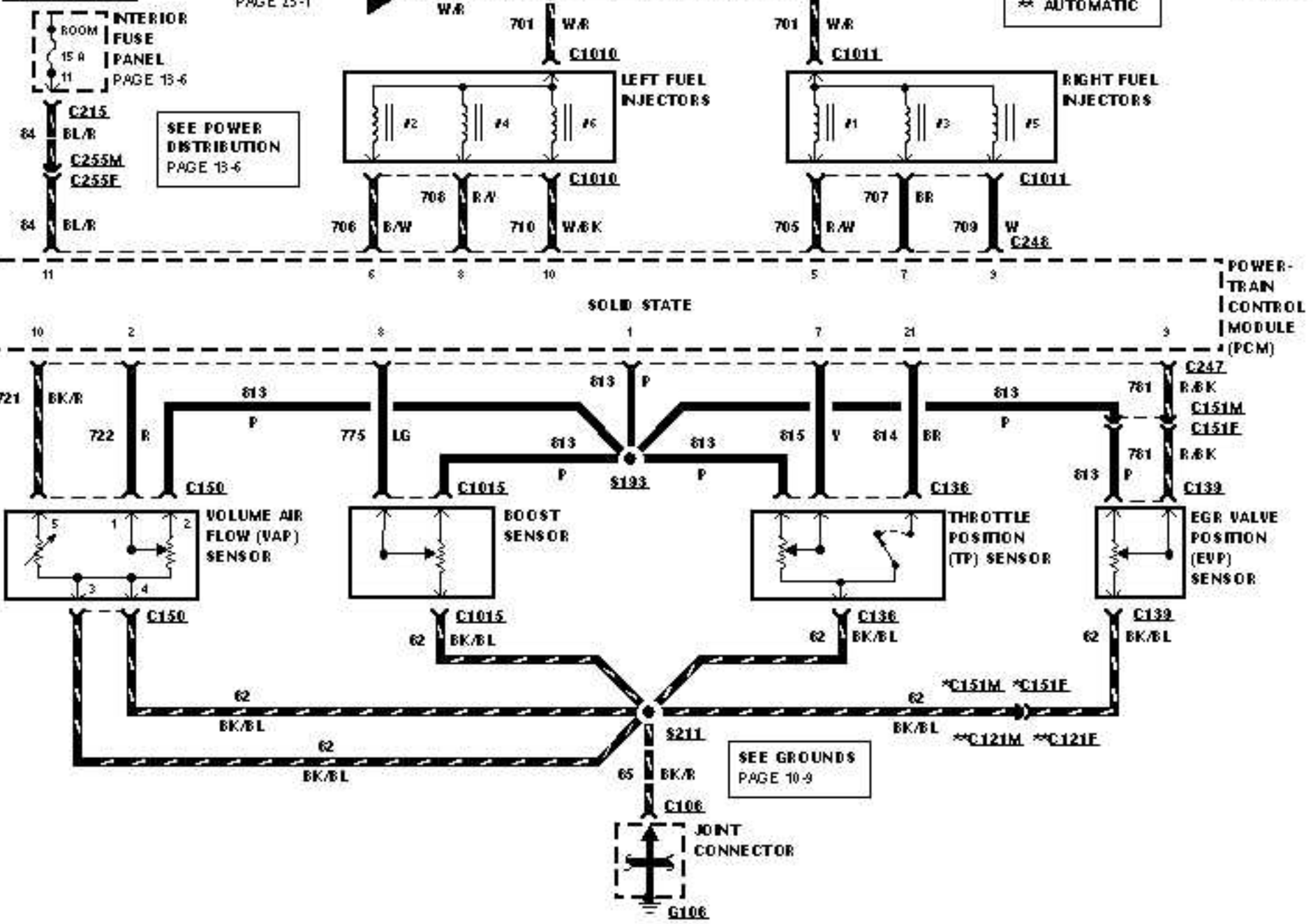

FROM
C180 ON
PAGE 25-1

702
R.&K

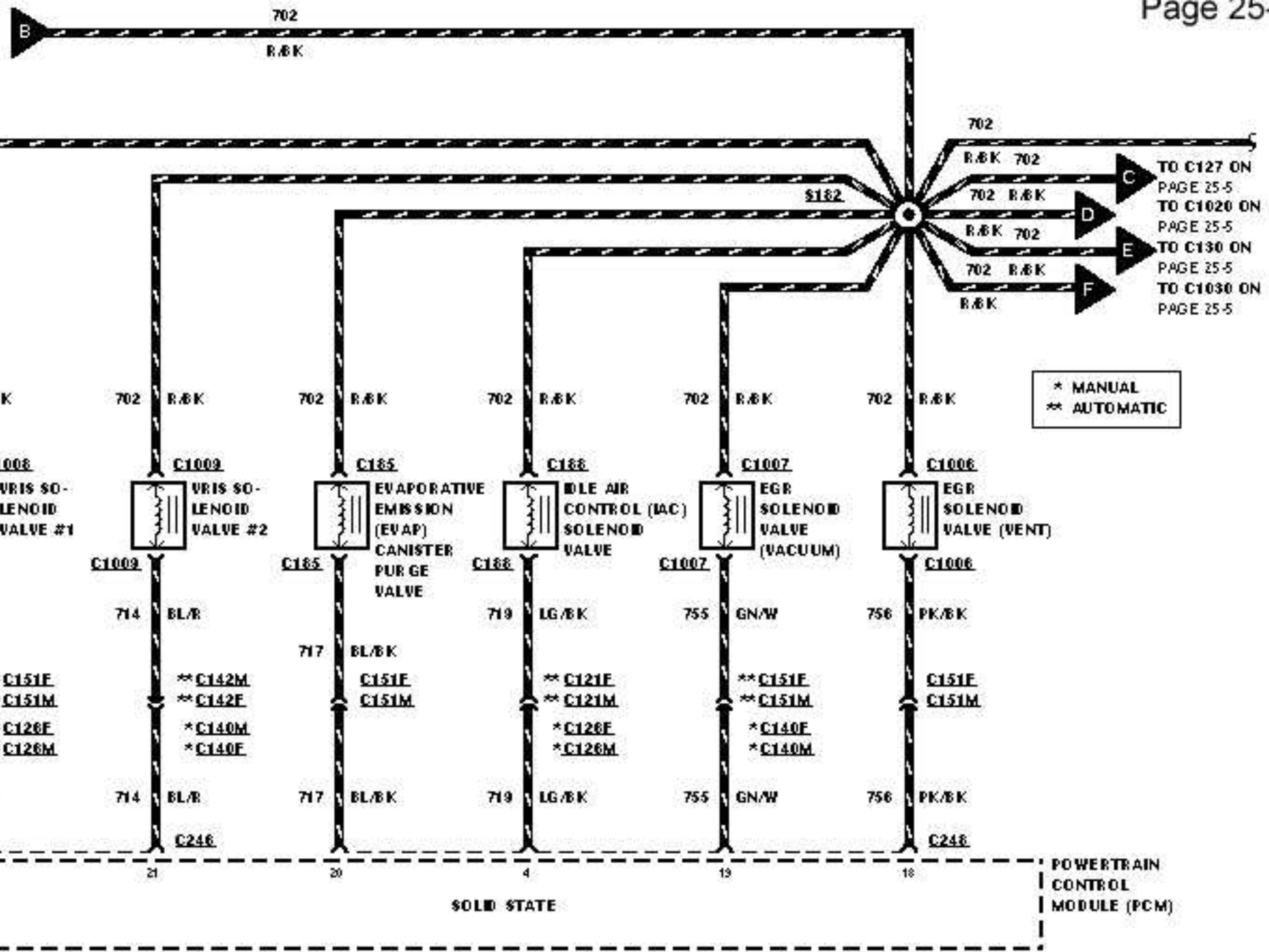

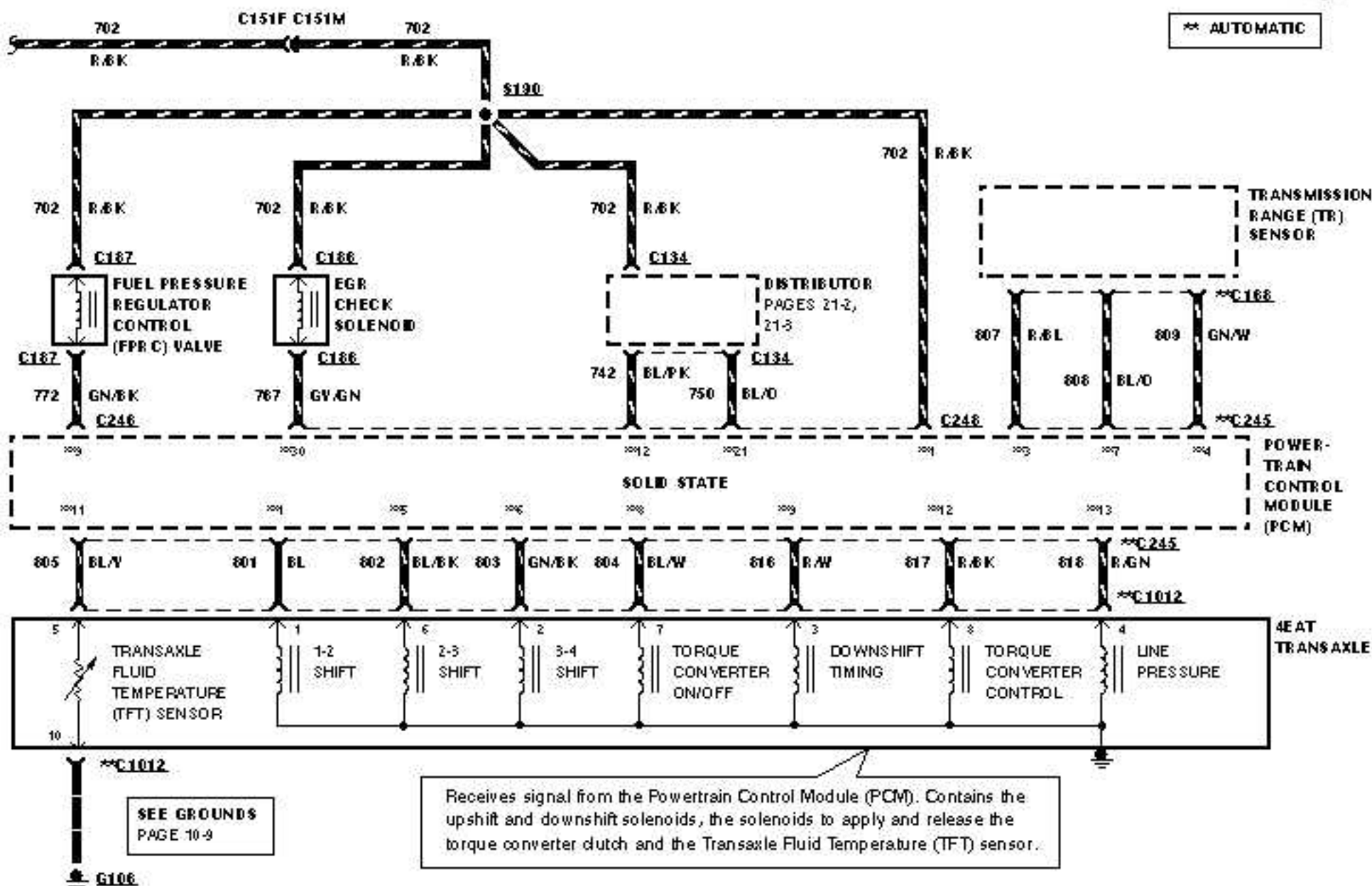

CRANKSHAFT POSITION
(CKP) SENSOR

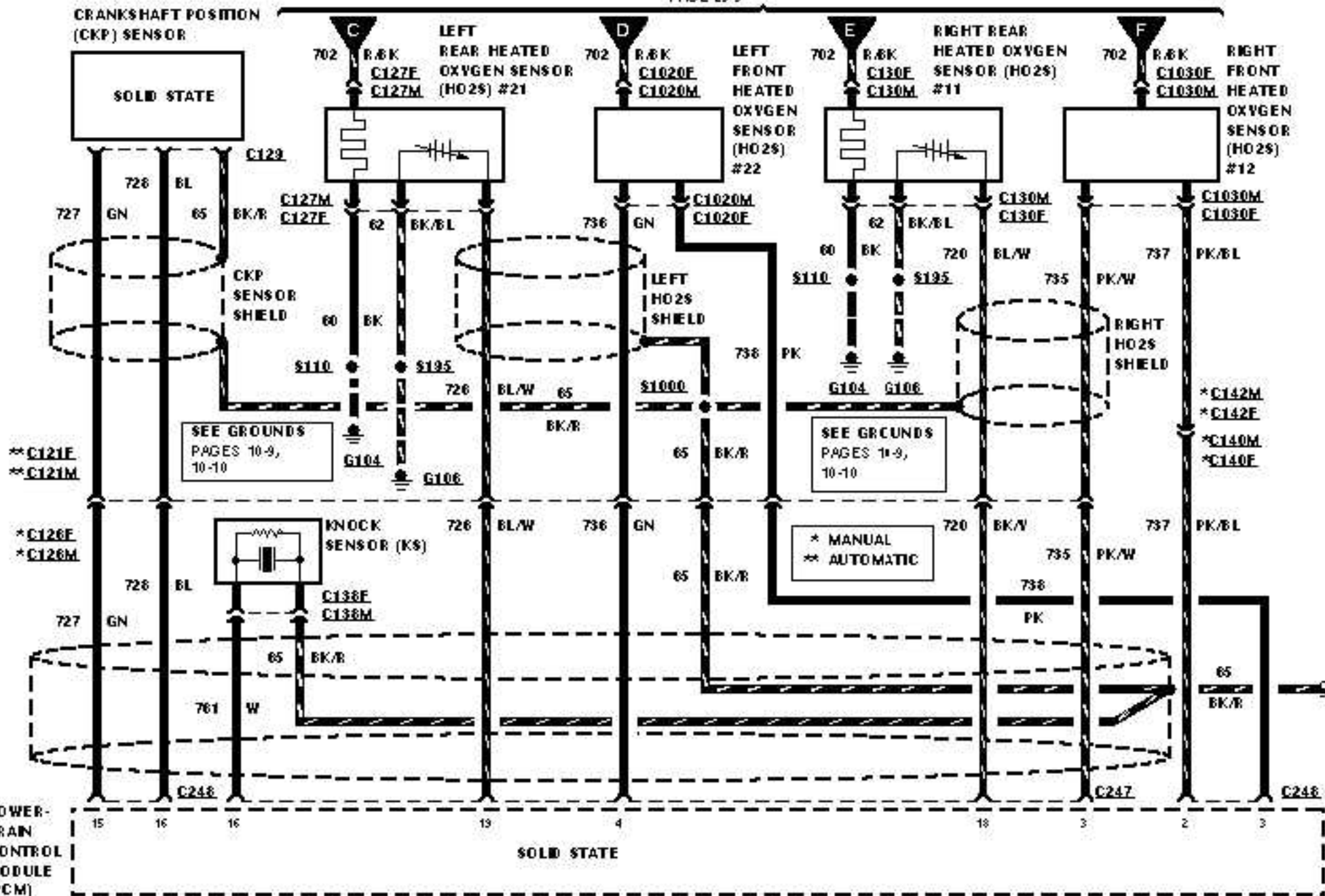

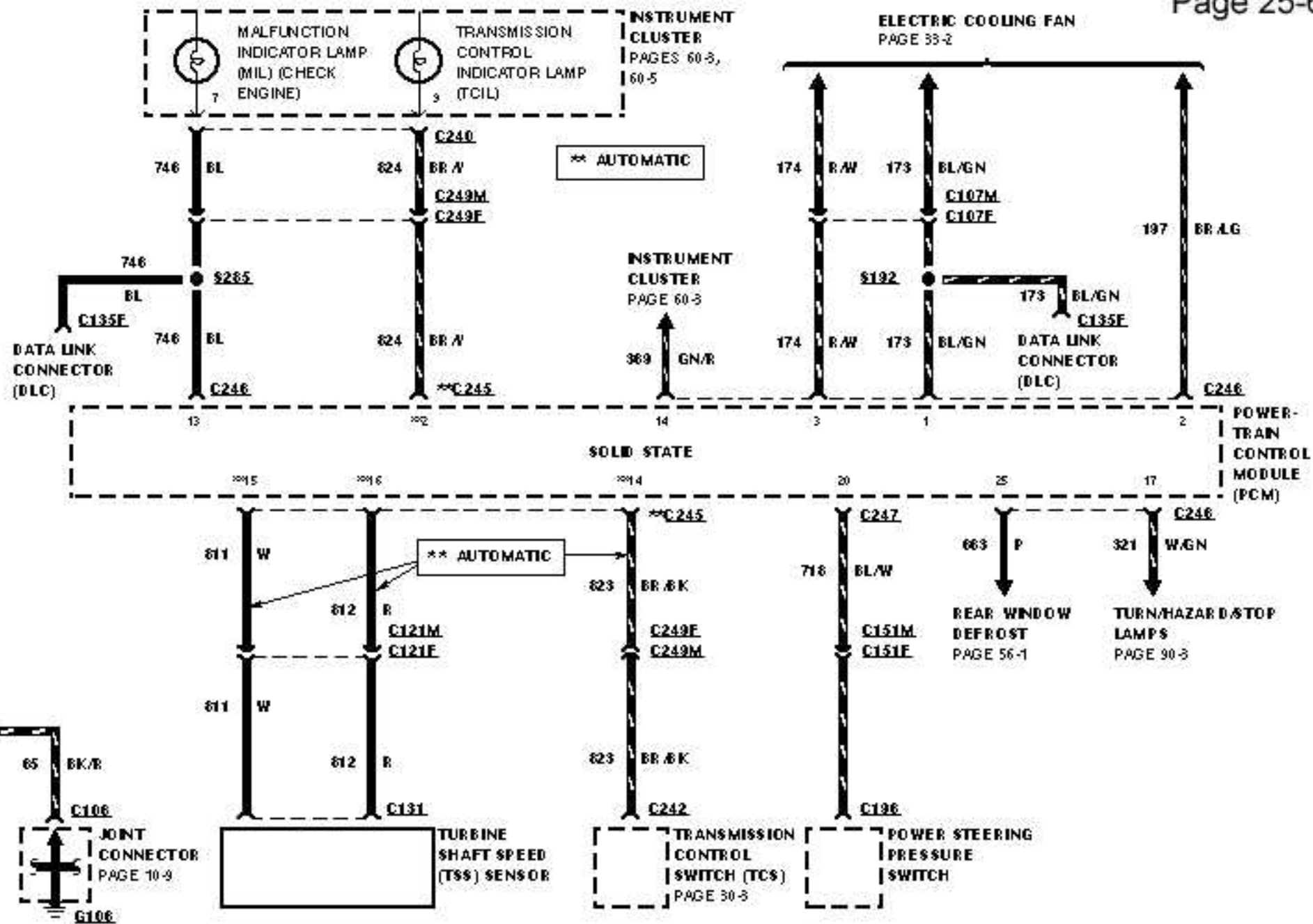



ENGINE COOLANT TEMPERATURE (ECT) SENSOR

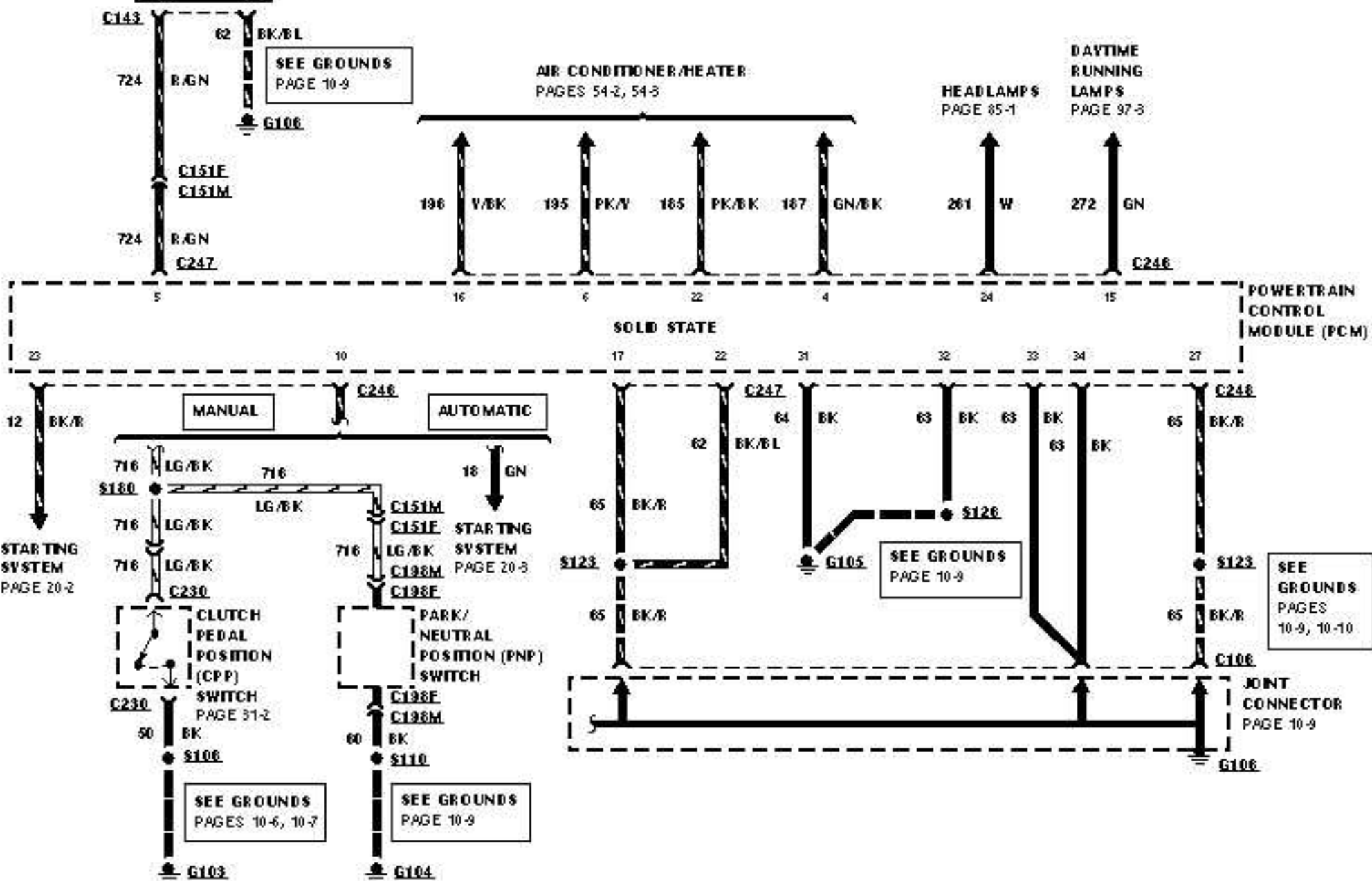

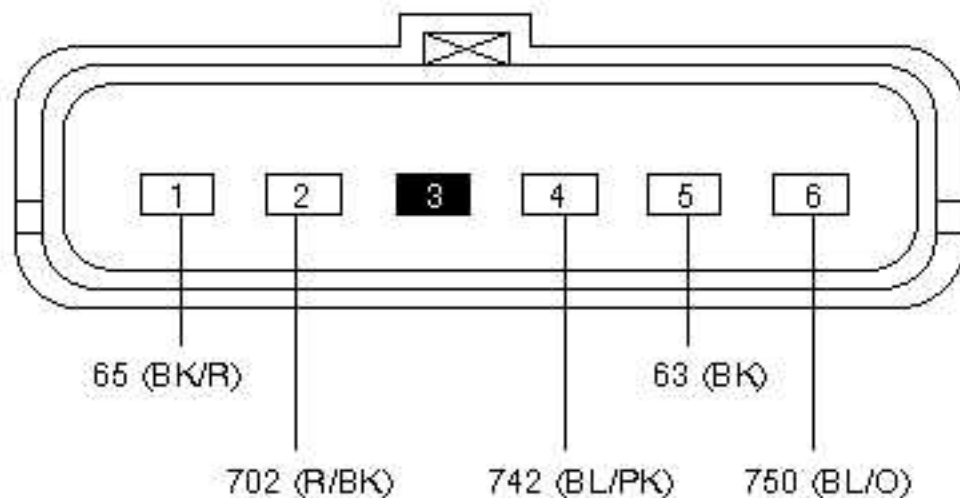

C134 (GRAY)

**DISTRIBUTOR
(2.5L)**

PIN	CIRCUIT	CIRCUIT FUNCTION
1	65 (BK/R)	Ground
2	702 (R/BK)	PCM Power Relay Input
3	-	NOT USED
4	742 (BL/PK)	Ground Signal (Cylinder Identification)
5	65 (BK)	Ground
6	750 (BL/O)	Distributor Ignition Input

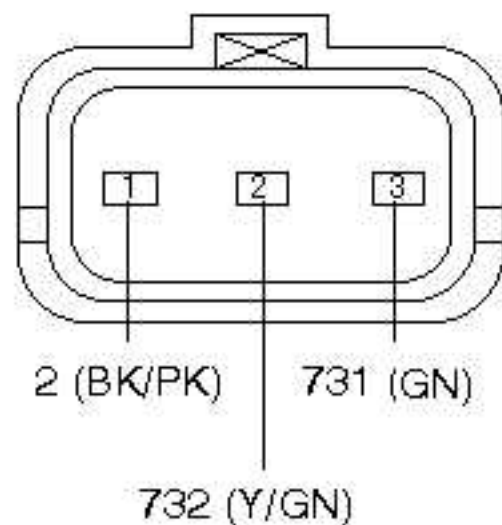

C170 (GRAY)
DISTRIBUTOR
(2.5L)

PIN	CIRCUIT	CIRCUIT FUNCTION
1	2 (BK/P)	Power (Hot in Start or Run)
2	732 (Y/GN)	Tachometer Signal (Ignition Ground)
3	731 (GN)	Tachometer Output

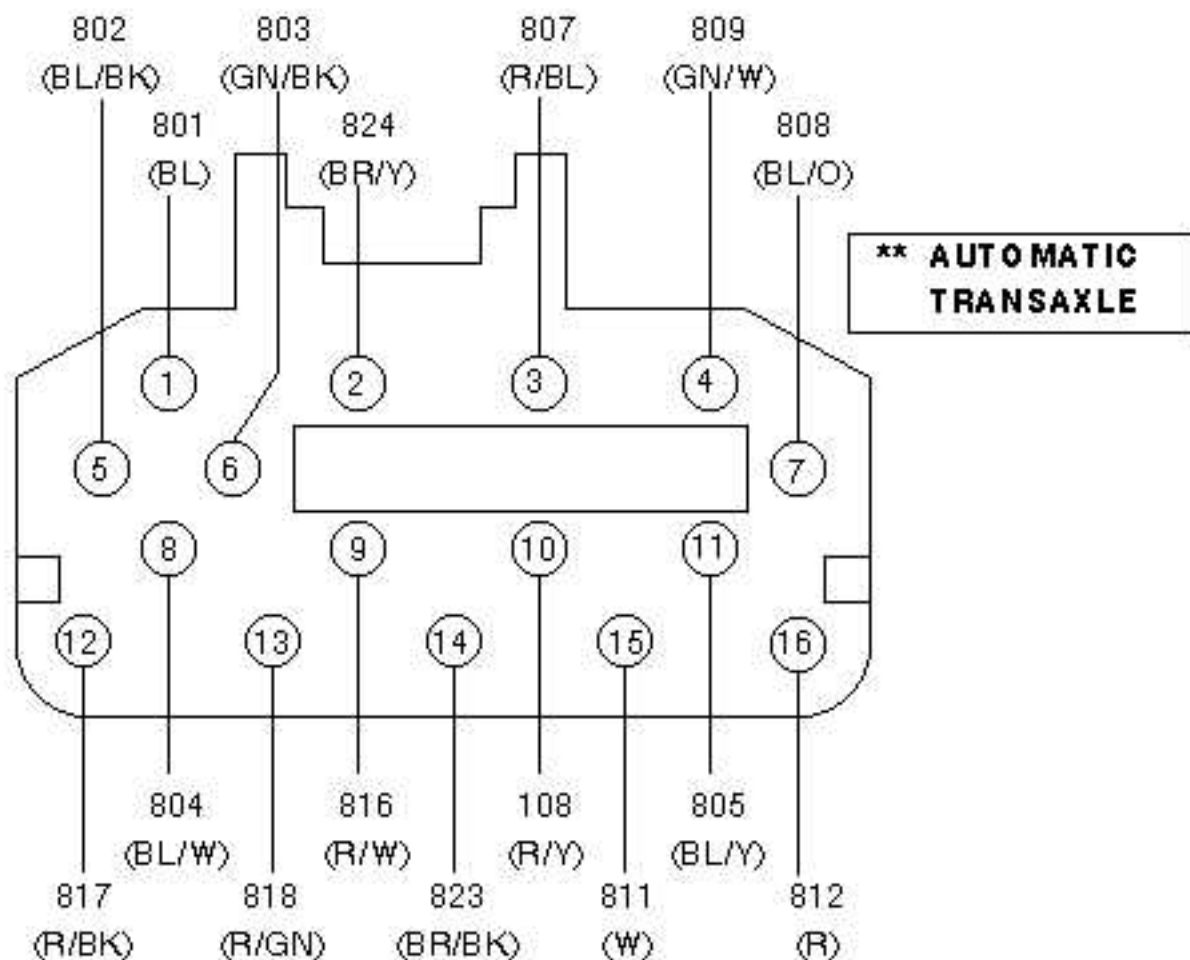

****C245**

POWERTRAIN CONTROL MODULE (PCM) (2.5L)

PIN	CIRCUIT	CIRCUIT FUNCTION
1	801 (BL)	1- 2 Shift Solenoid
2	824 (BR/Y)	TCIL
3	807 (R/BL)	Transmission Range (TR) Sensor
4	809 (GN/W)	Transmission Range (TR) Sensor
5	802 (BL/BK)	2- 3 Shift Solenoid
6	803 (GN/BK)	3- 4 Shift Solenoid
7	808 (BL/O)	Transmission Range (TR) Sensor
8	804 (BL/W)	Torque Converter ON/OFF
9	816 (R/W)	Downshift Timing Solenoid
10	108 (R/Y)	Transmission Range (TR) Sensor
11	805 (BL/Y)	Transaxle Fluid Temperature Sensor
12	817 (R/BK)	Torque Converter Control
13	818 (R/GN)	Line Pressure Solenoid
14	823 (BR/BK)	Transmission Control Switch
15	811 (W)	Turbine Shaft Speed Sensor (+)
16	812 (R)	Turbine Shaft Speed Sensor (-)

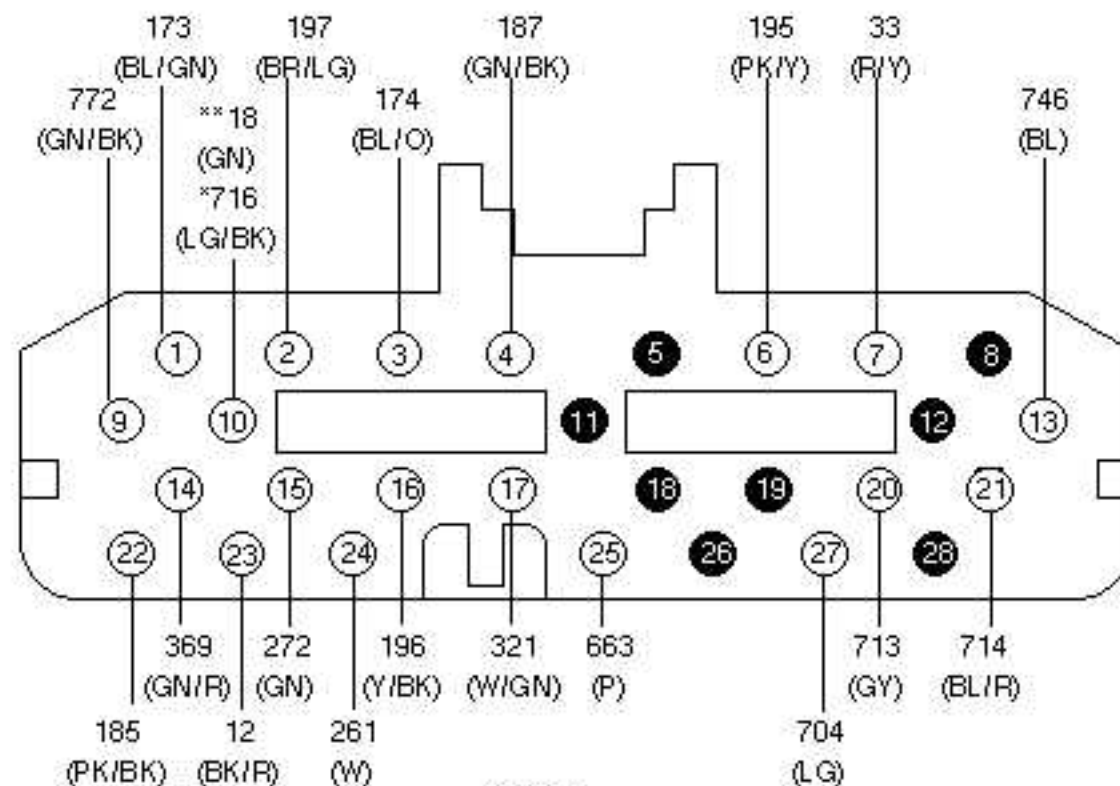

* MANUAL TRANSAXLE
 ** AUTOMATIC TRANSAXLE

POWERTRAIN CONTROL MODULE (PCM) (2.5L)

PIN	CIRCUIT	CIRCUIT FUNCTION	PIN	CIRCUIT	CIRCUIT FUNCTION
1	173 (BL/GN)	High Speed Fan Control	16	196 (Y/BK)	Blower Motor On Input
2	197 (BR/LG)	Low Speed Fan Control	17	321 (W/GN)	Brake On Input
3	174 (BL/G)	Low Fan Control	18	-	NOT USED
4	187 (GN/BK)	A/C Relay Output	19	-	NOT USED
5	-	NOT USED	20	713 (GY)	Variable Resonance Induction System (VRIS) Solenoid #1
6	195 (PK/Y)	A/C High Pressure Input	21	714 (BL/R)	Variable Resonance Induction System (VRIS) Solenoid #2
7	33 (R/Y)	Data Link Connector	22	185 (PK/BK)	A/C High Pressure Switch
8	-	NOT USED	23	12 (BK/R)	Start Signal Power
9	772 (GN/BK)	Fuel Pressure Regulator Control	24	261 (W)	Headlamps On Input
**10	18 (GN)	Transmission Range (TR) Sensor	25	663 (P)	Rear Window Defrost On Input
*10	716 (LG/BK)	Park/Neutral Position (PNP) Switch	26	-	NOT USED
11	-	NOT USED	27	704 (LG)	Fuel Pump Relay
12	-	NOT USED	28	-	NOT USED
13	746 (BL)	Malfunction Indicator Lamp (MIL)			
14	369 (GN/R)	Vehicle Speed Sensor (+)			
15	272 (GN)	Daytime Running Lamps Relay			

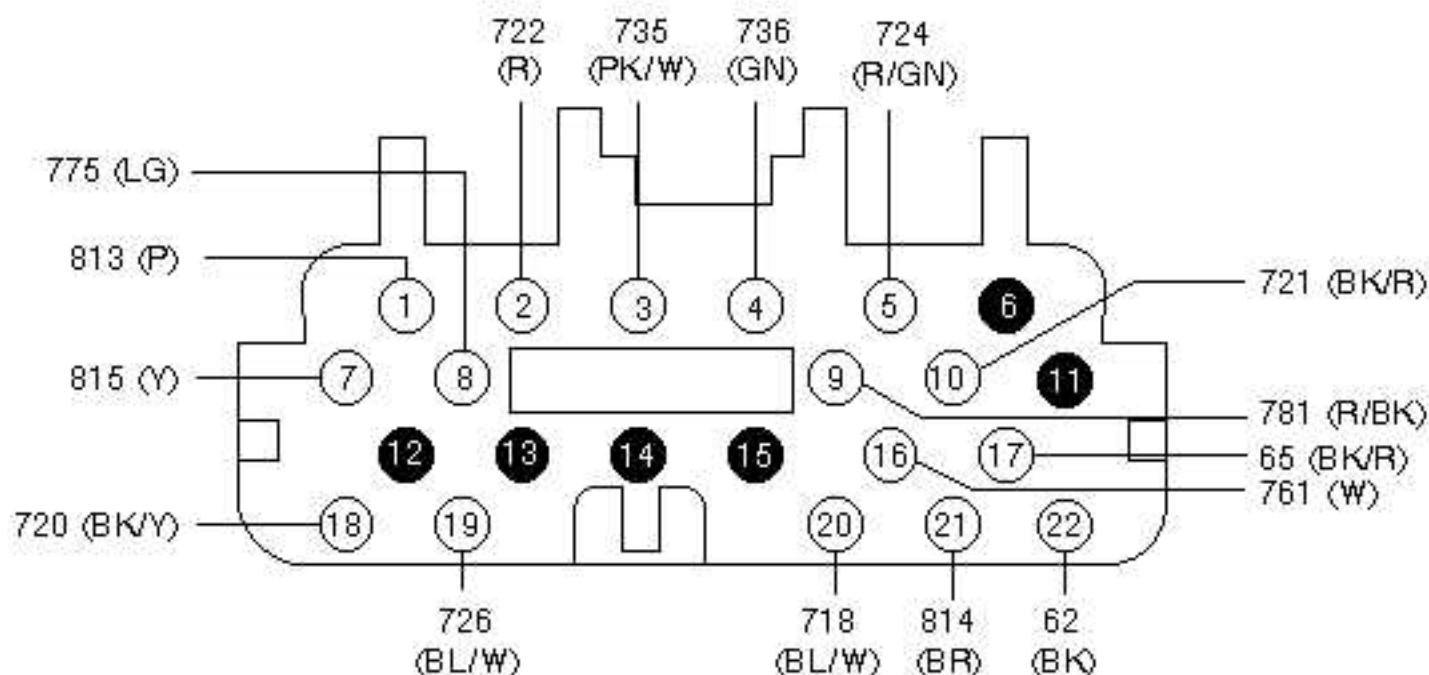

C247

POWERTRAIN CONTROL MODULE (PCM) (2.5L)

PIN	CIRCUIT	CIRCUIT FUNCTION
1	813 (P)	Reference Voltage (Output)
2	722 (R)	Volume Airflow Input
3	735 (PK/W)	Right Rear Heated Oxygen Sensor (HO2S)
4	736 (GN)	Left Rear Heated Oxygen Sensor (HO2S)
5	724 (R/GN)	Engine Coolant Temperature Sensor (ECTS)
6	-	NOT USED
7	815 (Y)	Throttle Position Input
8	775 (LG)	Boost Sensor
9	781 (R/BK)	EGR Position Sensor
10	721 (BK/R)	Volume Airflow Meter Input
11	-	NOT USED
12	-	NOT USED
13	-	NOT USED
14	-	NOT USED
15	-	NOT USED
16	761 (W)	Knock Sensor
17	65 (BK/R)	Ground
18	720 (BK/Y)	Right Front Heated Oxygen Sensor (HO2S)
19	726 (BL/W)	Left Front Heated Oxygen Sensor (HO2S)
20	718 (BL/W)	Power Steering Pressure Switch Input
21	814 (BR)	Closed Throttle Input
22	62 (BK)	Ground

* MANUAL
** AUTOMATIC

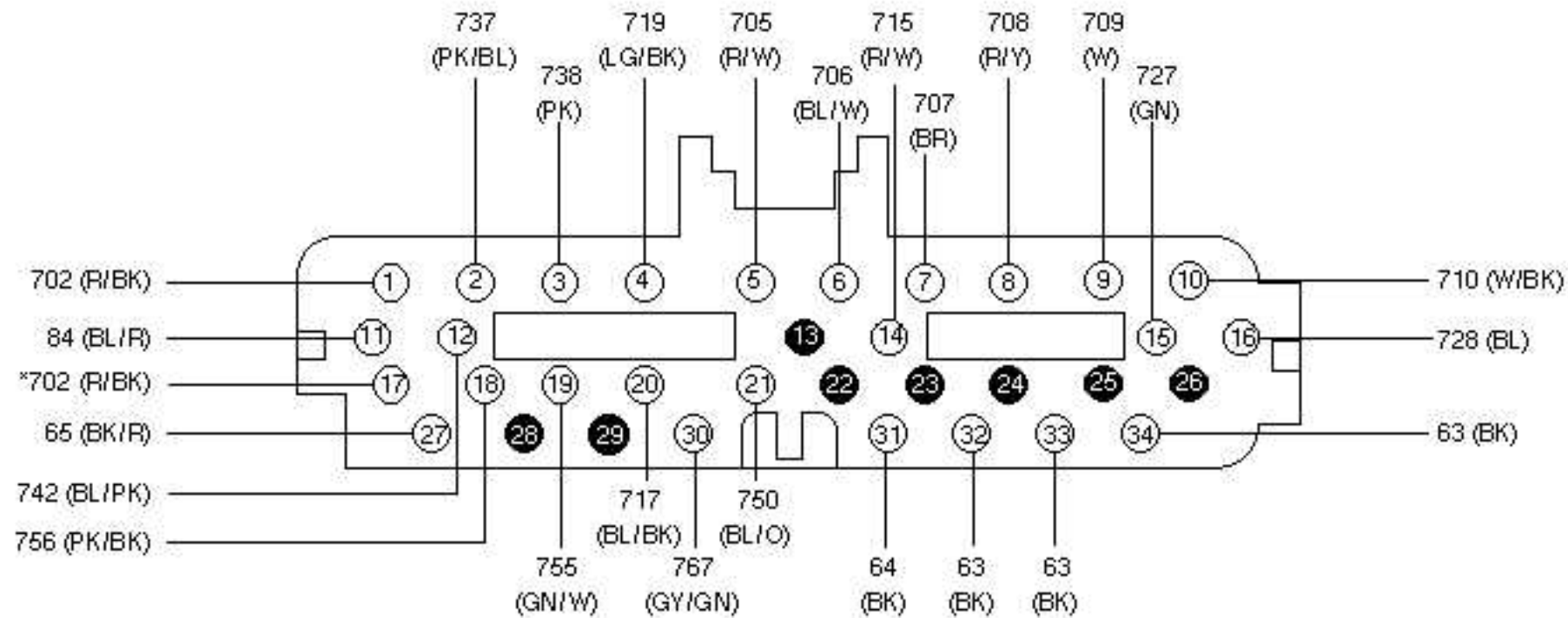

C248

POWERTRAIN CONTROL MODULE (PCM) (2.5L)

PIN	CIRCUIT	CIRCUIT FUNCTION	PIN	CIRCUIT	CIRCUIT FUNCTION
1	702 (R/BK)	Power	18	756 (PK/BK)	EGR Duty Solenoid (Vent)
2	757 (PK/BL)	Right Rear Heated Oxygen Sensor (HO2S)	19	755 (GN/W)	EGR Duty Solenoid (Vacuum)
3	738 (PK)	Left Rear Heated Oxygen Sensor (HO2S)	20	717 (BL/BK)	EVAP Canister Purge Valve
4	719 (LG/BK)	Idle Air Control Valve	21	850 (BL/O)	Distributor
5	705 (R/W)	Fuel Injector #1	22	-	NOT USED
6	706 (BL/W)	Fuel Injector #2	23	-	NOT USED
7	707 (BR)	Fuel Injector #3	24	-	NOT USED
8	708 (R/Y)	Fuel Injector #4	25	-	NOT USED
9	709 (W)	Fuel Injector #5	26	-	NOT USED
10	710 (W/BK)	Fuel Injector #6	27	65 (BK/R)	Ground
11	84 (BL/R)	Keep Alive Power	28	-	NOT USED
12	742 (BL/PK)	Diagnosis	29	-	NOT USED
13	-	NOT USED	30	767 (GY/GN)	EGR Check Solenoid
14	715 (R/W)	Data Link Connector	31	64 (BK)	Ground
15	727 (GN)	Crankshaft Position Sensor	32	63 (BK)	Ground
16	728 (BL)	Crankshaft Position Sensor	33	63 (BK)	Ground
*17	-	NOT USED	34	63 (BK)	Ground
**17	**702 (R/BK)	Power			